

REVISION			
REV.	DESCRIPTION	DATE	APPROVED
A	Changed Contact Quantity from 58 to 46	03-12-07	DP

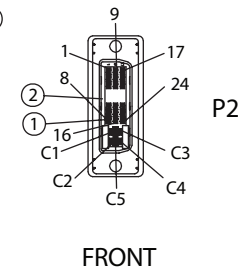

PIN OUT

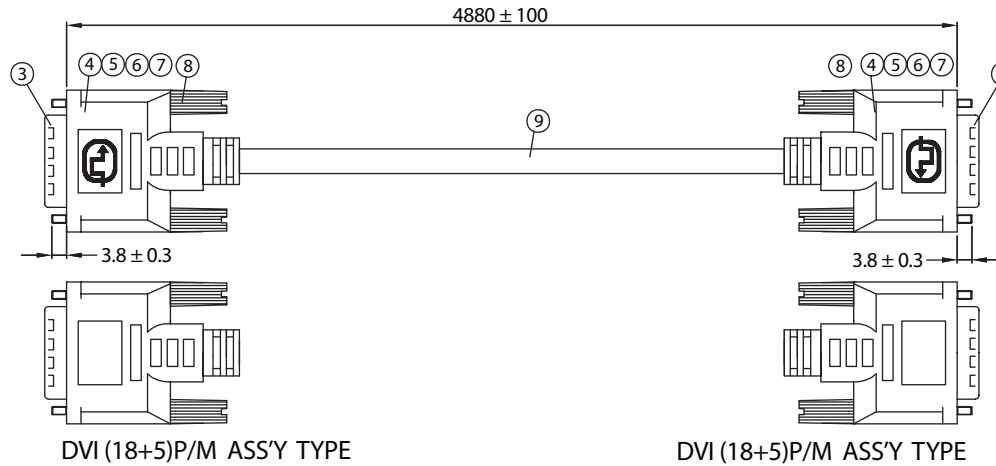
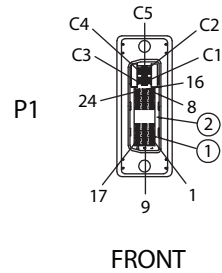
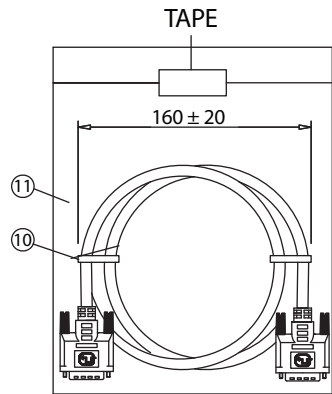
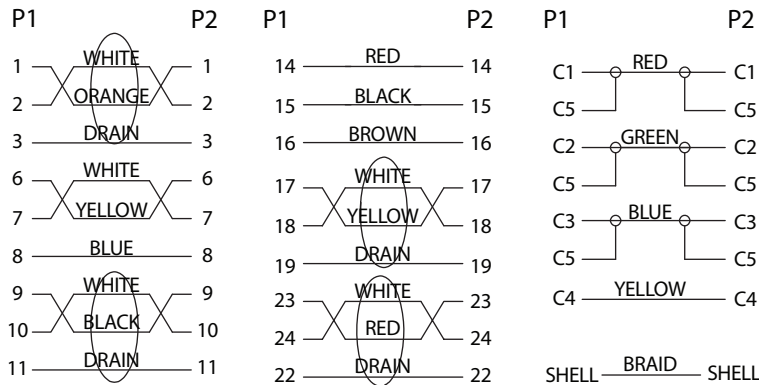

NOTES:

- CABLE:
UL 20276 28AWG
(28AWGx1P+DW+FOIL)x4P+(28AWG+SP+FOIL)x3C+28AWGx5C+28AWGx1P+MYLAR+FOIL+BD
OUTER JACKET COLOR: BLACK, OD: 8.5 ± 0.3mm
PRINTING: "E166307 AWM 20276 28AWG 80°C 30V VW-1
LOW VOLTAGE COMPUTER CABLE"
- CONNECTORS: DVI (18+5)P/M - DVI (18+5)P/M
- HOOD: ASS'Y TYPE
- CABLE ELECTRICAL TEST:
<1>.100% OPEN SHORT & MISS WIRE TEST
<2>.INSULATION RESISTANCE: DC400V 10M ohm MIN.
<3>.CONDUCTOR RESISTANCE: 1 ohm MAX.
- PACKING: 1PC/POLYBAG

No.	PARTS NAME	SPECIFICATION STANDARD	QTY	REMARKS
①	DVI (18+5)P/M - CONTACT	BRONZE/GOLD PLATED SOLDER TYPE	46	MAIN SUPER or EQUIV
②	DVI (18+5)P/M - INSULATOR	THERMOPLASTIC/BLACK UL94V-0	2	
③	DVI (18+5)P/M - SHELL	STEEL NICKEL PLATED	2	
④	COPPER FOIL	WIDTH: 8mm	2	
⑤	CAN	STEEL TIN PLATED ID:9.0mm	2	
⑥	OUTER COVER	45P PVC/BLACK(BK01) ID: 9.0mm	2	
⑦	THUMB SCREW	#4-40 2.8x45, NICKEL PLATED	4	
⑧	SCREW - MOLD	35P PVC/COLOR: BLACK	4	
⑨	CABLE DVI 18+5 UL20276	KL03008ABK01A	1	
⑩	MINI TIE	PE/BLACK	2	
⑪	POLYBAG	PE/0.08x220x260mm	1	

Dim range (mm)	Tolerance +/- (mm)	Qualtek Electronics Corp. WCT DIVISION		
		Part Number: 1321035-16		
0-1	0.15	Description: DVI(18+5)P/M - DVI(18+5)P/M		
1-6	0.20			
6-18	0.30	Rev. A		
18-50	0.50			
50-120	0.70	Drawn / Date	Checked / Date	Approved / Date
120-250	0.90	B.Grubb 01-25-07	01-25-07	JJH / 01-25-07
250-500	1.20			